

CHAPTER 4 OPERATOR MAINTENANCE AND CARE

1. SAFETY INSPECTION

Before using a lift truck, it is **the operator's responsibility** to check its condition and be sure it is safe to operate.

Check for damage and maintenance problems; have repairs made before you operate the truck. Unusual noises or problems must be reported immediately to your supervisor or other designated authority.

Do not make repairs yourself unless you are trained in lift truck repair procedures and authorized by your employer. Have a qualified mechanic make repairs using genuine HD HYUNDAI or HD HYUNDAI- approved parts.

- ▲ **Do not operate a truck if it needs to be repaired. If it is in an unsafe condition, remove the key and report the condition to the proper authority. If the truck becomes unsafe in any way while you are operating it, stop operating the truck, report the problem immediately, and have it corrected.**

Lift trucks should be inspected every eight hours, or at the start of each shift. In general, the daily inspection should include the **visual** and **functional checks** described on the followings.

- ▲ **Leaking hydraulic oil may be hot or under pressure. When inspecting a lift truck, wear safety glasses and do not check for leaks with bare hands.**

2. VISUAL CHECKS

※ **First, perform a visual inspection of the truck and its major components:**

1. Walk around your lift truck and take note of obvious damage that may have been caused by operation during the last shift.
2. Check that all capacity, safety, and warning plates or decals are attached and legible.
3. Make sure that battery is safely mounted on correct position. Check battery fastening devices for correct installation for preventing movement or tip over of battery. Check the battery connector for safety.

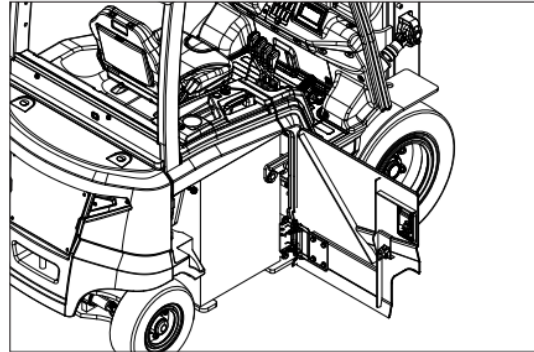

▲ **Check surroundings of driving axle for any external oil leak.**

4. Check for hydraulic oil leaks and loose fittings.

▲ **Oil may be hot or under pressure. Do not use bare hands to check.**

5. Be sure that the driver's overhead guard, load back rest and all other safety devices are in place, securely fastened and undamaged.
6. Check all of the critical components that handle or carry the load.
7. Look the mast and lift chains over.
Check for obvious wear and maintenance problems such as damaged or missing parts, leaks, slack or broken chains, rust, corrosion, bent parts, cracks, etc.
8. Carefully inspect the load forks for cracks, breaks, bending, twists, and wear. Be sure that the forks are correctly installed and locked in their proper position.
9. Inspect the wheels and tires for safe mounting, wear condition, and air pressure.
10. Check the hydraulic sump oil level, engine oil level, and fuel level.

3. FUNCTIONAL CHECKS

Check the operation of the truck as follows.

※ **Before performing these checks, familiarize yourself with the starting and operating procedures in Section 5 of this manual.**

1. Test warning devices, horn, light, and other safety equipment and accessories.
 2. Check self-diagnosis display, operation time indicator lamp, and remainder battery capacity indicator lamp with the truck started (dependent upon types of lift truck). Self-diagnosis display should indicate remainder capacity of battery, or failure code. If failure code is not an operator's failure code, contact service engineer.
 3. Check all of control devices and systems for normal operation, and returning to neutral positions:
 - 1) Service brake, parking brake
 - 2) Hydraulic pressure regulator: Lift, tilt and auxiliary system (if mounted)
 - 3) Acceleration pedal
 - 4) Forward and reverse driving device
 - 5) Steering systems
 - 6) Lift mechanism and any attachments
- Action after inspection**
- ① Fully stop the lift truck.
 - ② Return the forward and reverse levers to the neutral position.
 - ③ Apply the parking brake.
 - ④ Fully lower the attachment.
 - ⑤ Turn the start switch to OFF position.
- Action on stopped lift truck**
- ⑥ Remove the key from the starting switch.
 - ⑦ Lift truck may move on slope. Fix the wheels with base blocks.

4. CONCLUDING THE INSPECTION

Record all of inspection results or detected troubles, if any, on the operator's daily checklist, and provide the checklist to the maintenance engineers. Any abnormal noise or trouble should immediately be inspected.

Do not operate a lift truck that has a maintenance problem or is not safe to operate.

Instead, remove the key from the starting switch and put an Out of Service tag on the truck.

If all of the daily inspection checks were normal or satisfactory, the truck can be operated.

